

► DuraWeigh® 10" x 10" Bench Scale

Model 9202



Description

DuraWeigh® 10" x 10" heavy-duty bench scales are specially engineered for harsh washdown environments in food processing plants. They feature a robust design that truly solves scale performance deficiencies such as calibration accuracy, equipment durability and long-life performance.

DuraWeigh® 10" x 10" scales are NTEP-certified. They are specially engineered to prevent damage caused by punishing daily plant use, moisture, and chemical washdown sanitation procedures. Advanced sealing technology used on the IP69K-rated indicator, plus a heavy-gauge stainless steel base and super-strong keypad make these scales virtually waterproof.

Advantages and Benefits

- Water-resistant construction reduces lifetime ownership costs
- Designed to remain on the plant floor during washdown procedures, without any special handling
- Revolutionary Gainco Infiniti® indicator provides easy-view display, oversized buttons and "universal" symbols
- Super-resilient polymeric keypad is practically indestructible
- Easy-access wiring and load cells make inspection and service a cinch

Features

- Sanitary welded, open-frame stainless steel construction (7-gauge, 300 series SS)
- Scale base features open corners for drainage
- Environmentally protected stainless steel load cells with compression overload stops
- Easy access to "smart" components
- Built-in handle plus weigh platter retainer tab for easy portability anywhere in the plant

DuraWeigh® 10" x 10" Bench Scale – Model 9202

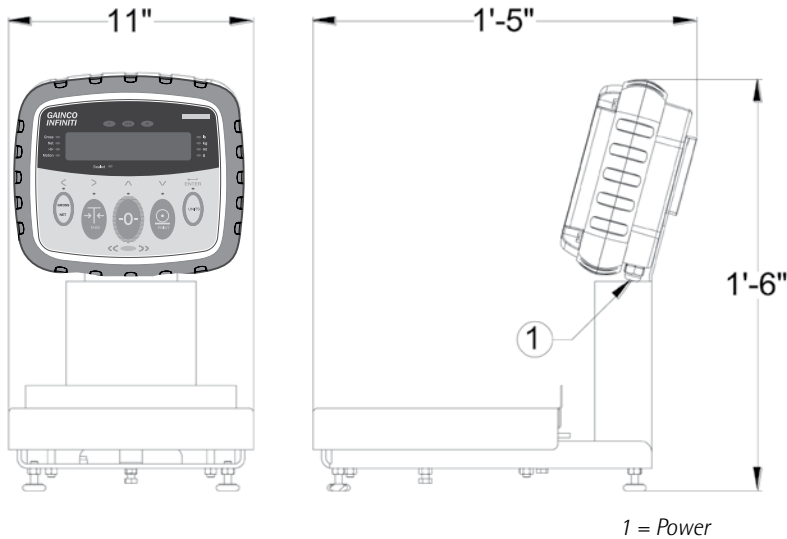

Options and Accessories

A variety of options are available to meet special requirements:

- 7.5 kg or 30 kg load cell capacity
- Ethernet, WiFi or Bluetooth® connectivity
- Stuffing horn option

For additional information on equipment specs, contact your Gainco technical sales representative or call toll-free **877-869-7410**.

Technical Specifications

Capacity	50 lbs
Accuracy	0.01% Full Scale
Resolution	Up to 5,000d
Weight Indicator	Gainco Infinity® LED
Display	6 Digit, 7 Segment
Annunciators	Gross, Net, Center of Zero Motion Lb, Kg, Oz, G Over, Under, OK
Keypad	5 - Touch (Capacitance) Sensitive Pads with Universal Symbols
Ingress Rating	IP69K for High Temp, High-Pressure Washdown
Width	11"
Height	1'6"
Depth	1'5"
Weigh Platter Dimensions	10" x 10"
Construction	Frame - 7 Gauge 300 Series SS
Serial	Bi-Directional RS 232 - 485
Wi-Fi	Optional
Bluetooth®	Optional
I/O	Optional
Remote Keys	2 - Configurable as Remote PRINT, ZERO, TARE, UNITS
AC Power	Universal 90 - 250 VAC 50/60 Hz
Power Usage	100ma @ 115 VAC
Battery	Long Life Lithium-Ion (Optional)



1635 Oakbrook Drive | Gainesville, GA 30507 USA
t.f. 877.869.7410 | p. 770.534.0703 | f. 770.534.4591
info@gainco.com | gainco.com

► *Success you can measure.*