

AccuFill® Table Bagger System

Model 3102 – Manual System



An advanced hygienic design plus accuracy and labor savings are built into this robust AccuFill® table bagging system. Quality control, fill-and-weigh and bagging all happen in one compact, user-friendly workstation.

A continuous flow of product is directed towards the inspection table – then visually inspected and moved into the hopper for precise weighing and bagging. The accumulation table allows product to be inspected and staged. Because the bagger is tucked under the table, no additional floor space is required.

The system's IP69K-rated, washdown-tough *Gainco Infiniti*® programmable controller is perfect for harsh processing environments.

"Auto-zero" software automatically adjusts for any product accumulation on the hopper surfaces, assuring precision weighing accuracy. Battery-pack memory records the total number of bags, total weight, plus all setup parameters. An optional host PC can be connected to the system for reporting, setup control and yield analysis.

Advantages and Benefits

- High return on investment
- Labor savings – combining three functions into one compact workstation
- Real-time process reporting
- Maintenance-friendly ... easy accessibility for service

Features

- *Gainco Infiniti*® programmable controller
- Quick-change wicket holder for rapid reloading of bags
- Adjustable lower and upper limits, as well as weigh set-points
- Small footprint
- AMI sanitary design
- Wi-Fi connectivity
- Ethernet
- Fully integrates with optional proprietary data management software program

Technical Specifications

Capacity	Up to 6 bags/min
Throughput	Up to 90 lbs/min
Accuracy	+/- 0.1% of the true product weight, 99.5% of the time
Controller Type	Gainco Infniti® – Programmable
No. of Controllers	1
Installed Power	120 volts
Air Connection	3/8" hose or 1/2" NPT
Air Consumption	80 PSI / 3.5 CFM
Water Connections	None
Water Consumption	None
Wi-Fi Option	Yes
Data Management	Yes, Optional
Report Generation	Yes, Optional
Width	27.3"
Depth or Length	27.4"
Height (to Table)	46.5"
Height (to Top of Indicator)	58.9"

AccuFill® Table Bagger System

Model 3102

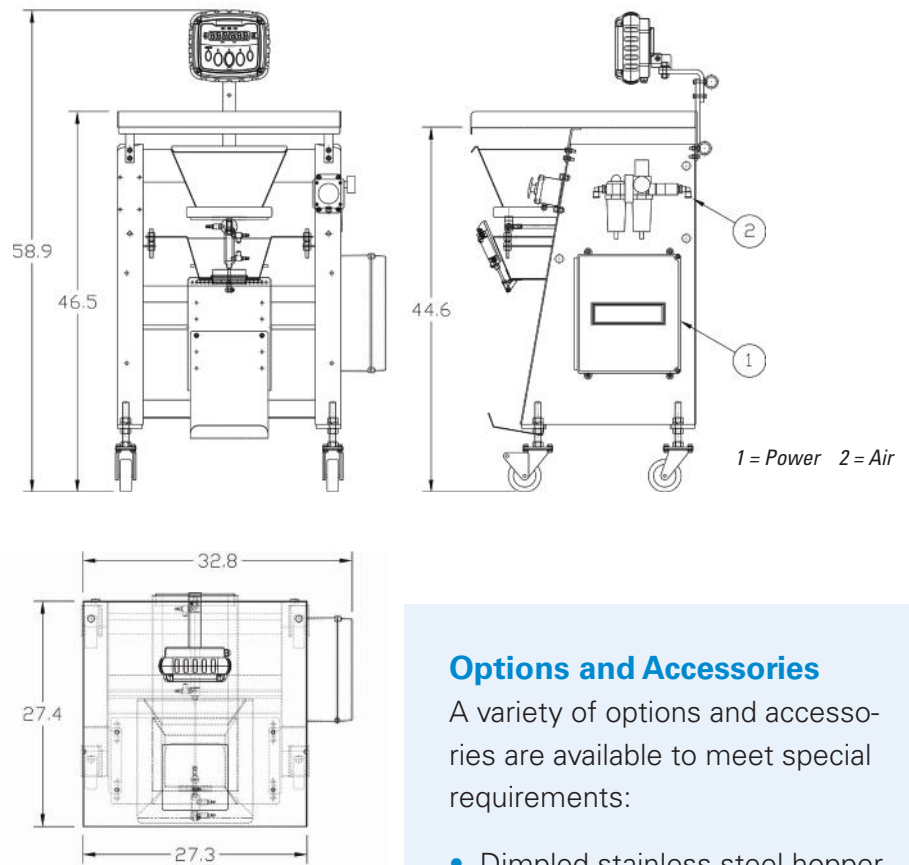

Options and Accessories

A variety of options and accessories are available to meet special requirements:

- Dimpled stainless steel hopper
- Ethernet or Wi-Fi communication
- Air clutch control valve, variable frequency drive and dry-contact relay line conveying controls
- Labeling system interface
- Datamax® or Zebra® printers
- Accessories: Spare wicket holder ... infeed conveyor

For additional information on equipment specs, contact your Cantrell•Gainco technical sales representative or call toll-free **800.467.2828**. Or, email your request to info@cantrellgainco.com.



▶ **Success you can measure.™**



Gainesville, GA USA | toll-free: 800.467.2828 | p: 770.534.0703 | info@cantrellgainco.com | cantrellgainco.com

AccuFill and Gainco Infniti are trademarks of Cantrell•Gainco Group. Datamax is a registered trademark of Datamax Corporation. Zebra is a registered trademark of Zebra Technologies Corporation. ©2020 Cantrell•Gainco Group. All rights reserved.